

# Reflective Optical Sensor with Transistor Output

## Description

The TCRT5000(L) has a compact construction where the emitting-light source and the detector are arranged in the same direction to sense the presence of an object by using the reflective IR beam from the object. The operating wavelength is 950 nm. The detector consists of a phototransistor.

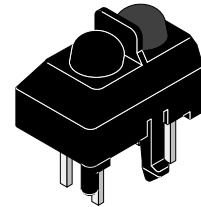

94 9442

## Applications

- Position sensor for shaft encoder
- Detection of reflective material such as paper, IBM cards, magnetic tapes etc.
- Limit switch for mechanical motions in VCR
- General purpose – wherever the space is limited

## Features

- Snap-in construction for PCB mounting
- Package height: 7 mm
- Plastic polycarbonate housing construction which prevents crosstalk
- L = long leads
- **Current Transfer Ratio (CTR)** of typical 10%

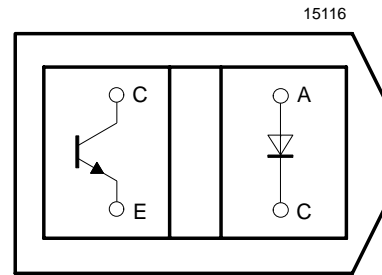

Top view

## Order Instruction

Ordering Code	Sensing Distance	Remarks
TCRT5000	12 mm	Leads (3.5 mm)
TCRT5000(L)	12 mm	Long leads (15 mm)



### Absolute Maximum Ratings

#### Input (Emitter)

Parameter	Test Conditions	Symbol	Value	Unit
Reverse voltage		$V_R$	5	V
Forward current		$I_F$	60	mA
Forward surge current	$t_p \leq 10 \mu\text{A}$	$I_{FSM}$	3	A
Power dissipation	$T_{amb} \leq 25^\circ\text{C}$	$P_V$	100	mW
Junction temperature		$T_j$	100	$^\circ\text{C}$

#### Output (Detector)

Parameter	Test Conditions	Symbol	Value	Unit
Collector emitter voltage		$V_{CEO}$	70	V
Emitter collector voltage		$V_{ECO}$	5	V
Collector current		$I_C$	100	mA
Power dissipation	$T_{amb} \leq 55^\circ\text{C}$	$P_V$	100	mW
Junction temperature		$T_j$	100	$^\circ\text{C}$

#### Sensor

Parameter	Test Conditions	Symbol	Value	Unit
Total power dissipation	$T_{amb} \leq 25^\circ\text{C}$	$P_{tot}$	200	mW
Operation temperature range		$T_{amb}$	-25 to +85	$^\circ\text{C}$
Storage temperature range		$T_{stg}$	-25 to +100	$^\circ\text{C}$
Soldering temperature	2 mm from case, $t \leq 10 \text{ s}$	$T_{sd}$	260	$^\circ\text{C}$

## Electrical Characteristics ( $T_{amb} = 25^{\circ}\text{C}$ )

### Input (Emitter)

Parameter	Test Conditions	Symbol	Min.	Typ.	Max.	Unit
Forward voltage	$I_F = 60 \text{ mA}$	$V_F$		1.25	1.5	V
Junction capacitance	$V_R = 0 \text{ V}$ , $f = 1 \text{ MHz}$	$C_j$		50		pF

### Output (Detector)

Parameter	Test Conditions	Symbol	Min.	Typ.	Max.	Unit
Collector emitter voltage	$I_C = 1 \text{ mA}$	$V_{CEO}$	70			V
Emitter collector voltage	$I_E = 100 \mu\text{A}$	$V_{ECO}$	7			V
Collector dark current	$V_{CE} = 20 \text{ V}$ , $I_F = 0$ , $E = 0$	$I_{CEO}$		10	200	nA

### Sensor

Parameter	Test Conditions	Symbol	Min.	Typ.	Max.	Unit
Collector current	$V_{CE} = 5 \text{ V}$ , $I_F = 10 \text{ mA}$ , $D = 12 \text{ mm}$	$I_C^{1,2)}$	0.5	1	2.1	mA
Collector emitter saturation voltage	$I_F = 10 \text{ mA}$ , $I_C = 0.1 \text{ mA}$ , $D = 12 \text{ mm}$	$V_{CEsat}^{1,2)}$			0.4	V

1) See test circuit

2) Test surface: Mirror (Mfr. Spindler a. Hoyer, Part No 340005)

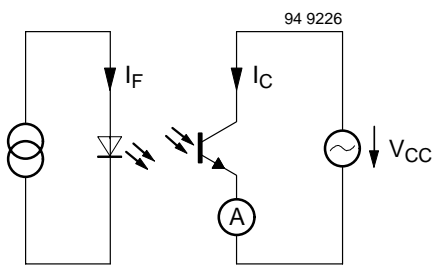

Figure 1. Test circuit

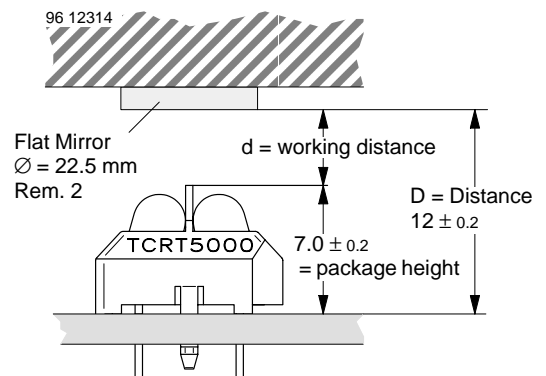

Figure 2. Test circuit

## Typical Characteristics ( $T_{amb} = 25^{\circ}\text{C}$ , unless otherwise specified)

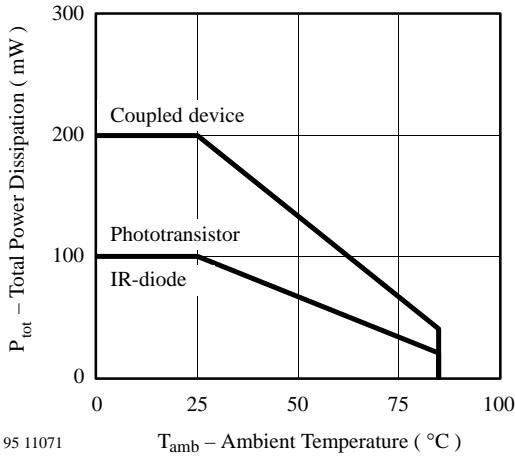

Figure 3. Total Power Dissipation vs. Ambient Temperature

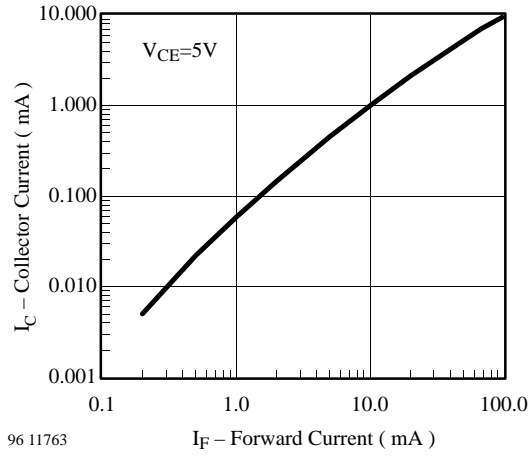

Figure 6. Collector Current vs. Forward Current

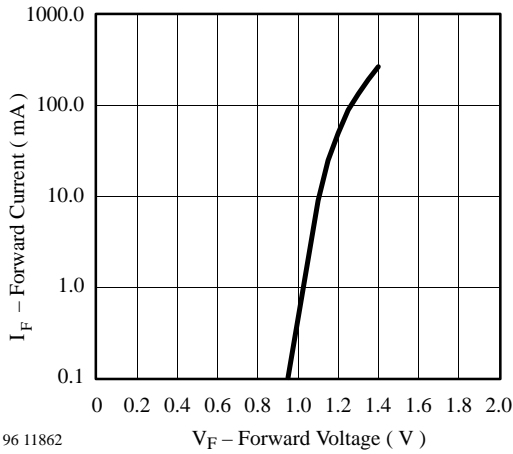

Figure 4. Forward Current vs. Forward Voltage

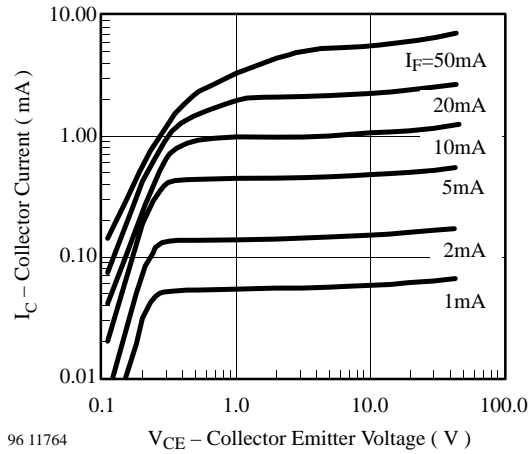

Figure 7. Collector Emitter Saturation Voltage vs. Collector Current

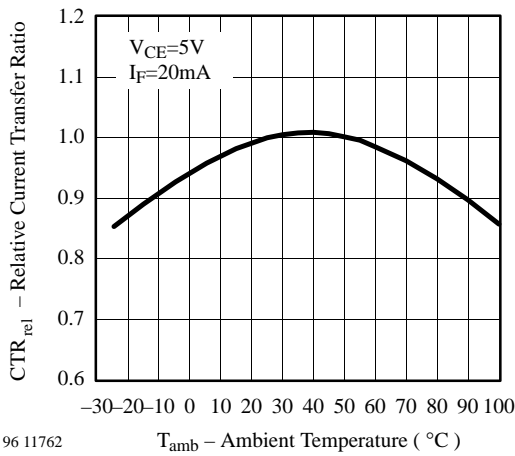

Figure 5. Rel. Current Transfer Ratio vs. Ambient Temp.

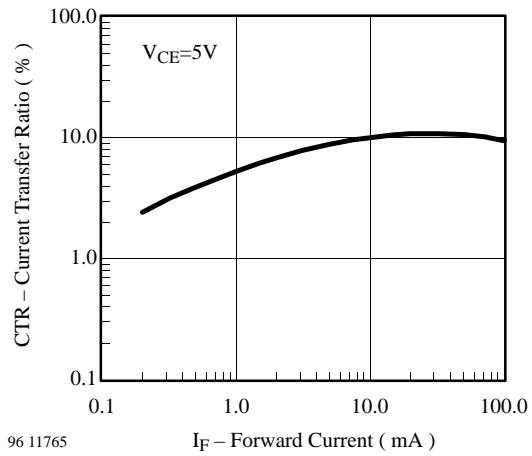

Figure 8. Current Transfer Ratio vs. Forward Current

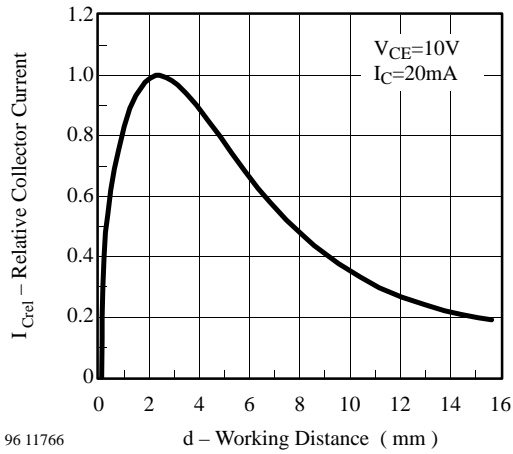
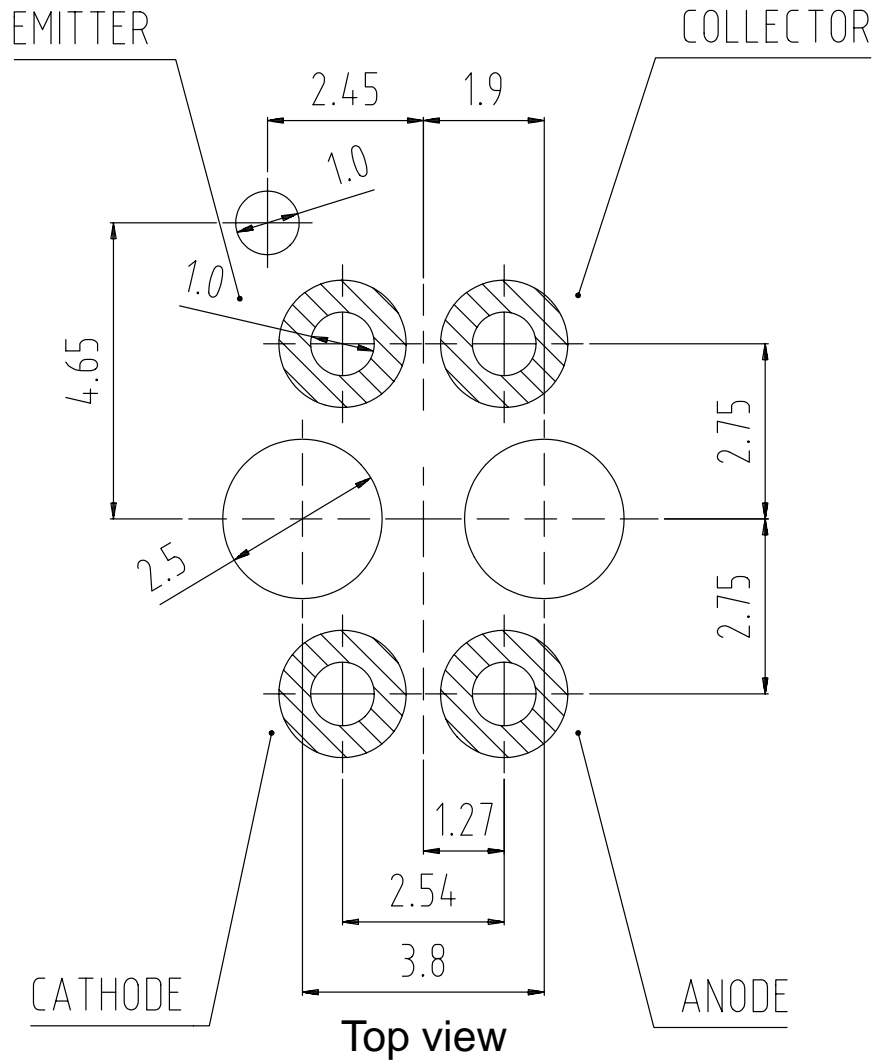

Figure 9. Relative Collector vs. Distance



Top view

Figure 10. Footprint

96 12371

# TCRT5000(L)

Vishay Semiconductors



## Dimensions of TCRT5000 in mm

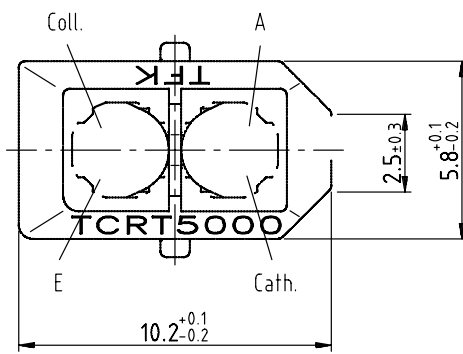
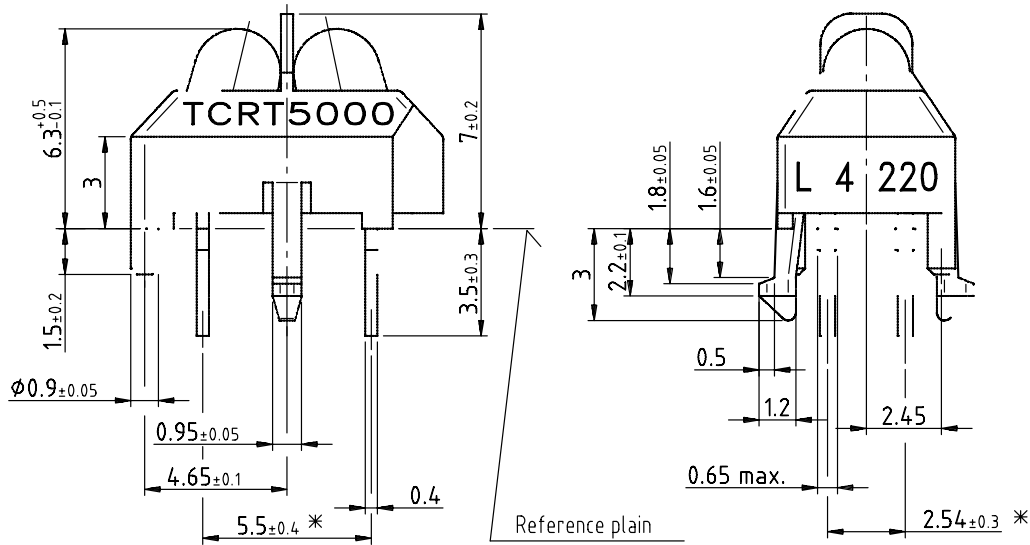

\* Tolerances related to reference plain

weight: ca. 0.23g

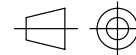

technical drawings according to DIN specifications

Footprint Top View

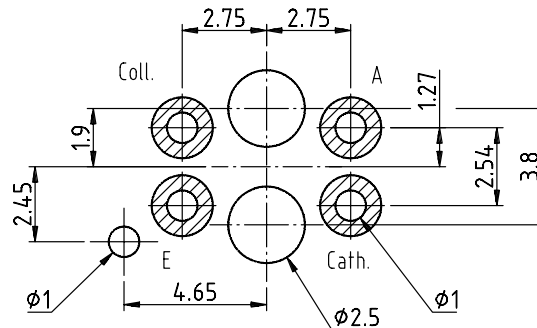

96 12073

Drawing-No.: 6.550-5096.01-4

Issue: 3; 28.06.00



### Ozone Depleting Substances Policy Statement

It is the policy of **Vishay Semiconductor GmbH** to

1. Meet all present and future national and international statutory requirements.
2. Regularly and continuously improve the performance of our products, processes, distribution and operating systems with respect to their impact on the health and safety of our employees and the public, as well as their impact on the environment.

It is particular concern to control or eliminate releases of those substances into the atmosphere which are known as ozone depleting substances (ODSs).

The Montreal Protocol (1987) and its London Amendments (1990) intend to severely restrict the use of ODSs and forbid their use within the next ten years. Various national and international initiatives are pressing for an earlier ban on these substances.

**Vishay Semiconductor GmbH** has been able to use its policy of continuous improvements to eliminate the use of ODSs listed in the following documents.

1. Annex A, B and list of transitional substances of the Montreal Protocol and the London Amendments respectively
2. Class I and II ozone depleting substances in the Clean Air Act Amendments of 1990 by the Environmental Protection Agency (EPA) in the USA
3. Council Decision 88/540/EEC and 91/690/EEC Annex A, B and C (transitional substances) respectively.

**Vishay Semiconductor GmbH** can certify that our semiconductors are not manufactured with ozone depleting substances and do not contain such substances.

**We reserve the right to make changes to improve technical design and may do so without further notice.**

Parameters can vary in different applications. All operating parameters must be validated for each customer application by the customer. Should the buyer use Vishay Semiconductors products for any unintended or unauthorized application, the buyer shall indemnify Vishay Semiconductors against all claims, costs, damages, and expenses, arising out of, directly or indirectly, any claim of personal damage, injury or death associated with such unintended or unauthorized use.

Vishay Semiconductor GmbH, P.O.B. 3535, D-74025 Heilbronn, Germany  
Telephone: 49 (0) 7131 67 2831, Fax number: 49 (0) 7131 67 2423